

ROLE OF DYNAMIC VOLTAGE RESTORER IN POWER QUALITY – A REVIEW

¹Balwant Barkhaniya, ²Madhu Upadhyay

¹M.Tech. Scholar, Department of Electrical Engineering, NRI Institute of Research & Technology, Bhopal

²Head, Department of Electrical Engineering, NRI Institute of Research & Technology, Bhopal

Abstract - Dynamic Voltage Restorer (DVR) is a modern and key custom power device to maintain the power quality. The DVR is a series compensator implemented to mitigate voltage sags and swell and to restore load voltage to its rated value. The Dynamic Voltage Restorer (DVR) is of high dynamic response, flexible and efficient solution to voltage sag and swell problem finally power quality problems using a robust in-phase compensation strategy for series voltage injection, the DVR dynamically corrects large voltage sags and swells in only a few cycles. In this paper a review of previously reported literature is given in terms of DVR function, location and operating modes

Key Words: Dynamic Voltage Restorer, Power Quality, Voltage Sag, Voltage swell

1. INTRODUCTION:

Power quality is one of the key concerns in the current renewable connected power grid due to the introduction of sophisticated devices, whose performance is very sensitive to the quality of power supply. Power quality problem is an occurrence

manifested as a non standard voltage current or frequency that results in a failure of end use equipments. Sensitive industrial loads and utility distribution networks all suffer from a variety of types of outages and service interruption which may root important economic loss. So there is a need of a prompt compensator to work against power quality issues like voltage sag and voltage swell.

- **Voltage Sag:** A Voltage Sag is a momentary decrease in the root mean square (RMS) voltage between 0.1 to 0.9 per unit, with a duration ranging from half cycle up to 1 min. It is considered as the most serious problem of power quality. It is caused by faults in the power system or by the starting of large induction motor [1].
- **Voltage Swell:** Voltage swell is defined as an increase in the root mean square (RMS) voltage from 1.1 to 1.8 per unit for duration from 0.5 cycles to 1 min. Voltage swells are not as important as voltage sags because they are less common in distribution systems. The main causes for voltage swell are switching of large capacitors or start/stop of heavy loads [3,4].

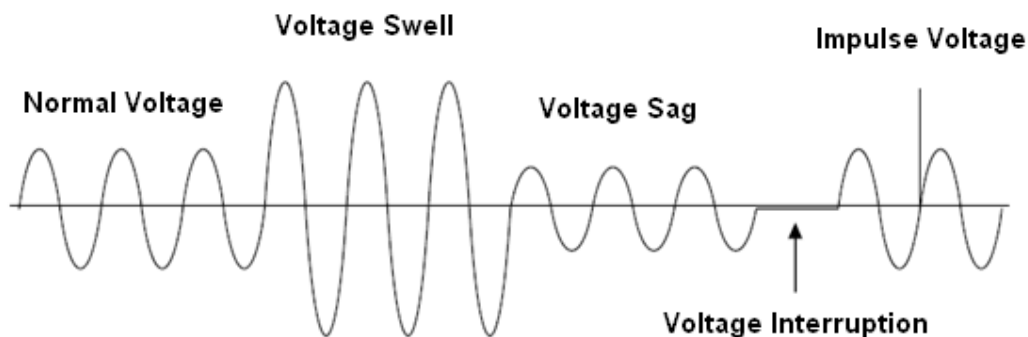

Fig. 1 Regular power- quality problems in power system

2. DYNAMIC VOLTAGE RESTORER:

Dynamic Voltage Restorer (commonly called DVR) is a commonly used power electronics device to mitigate the effects of voltage dips. The major advantage of the DVR

is that it has an energy store which provides the boost to the voltage during a dip. DVR is fast, flexible and offers a cost effective resolution for the shield of sensitive loads from voltage sags and swell problems

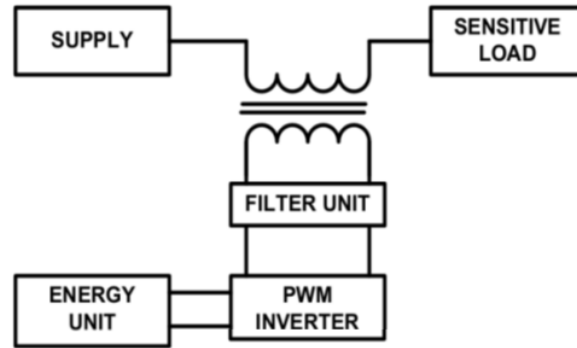

Fig. 2 The schematic of DVR with basic components

The basic features of Dynamic Voltage Restorer (DVR) are discussed below.

1. Lesser price, smaller size, and its fast dynamic response to the trouble.
2. Capability to control active power flow.
3. Superior energy capacity and lower costs compared to the SMES device.
4. Less maintenance required. Unlike UPS based regulators which are costly as it requires a significantly high level of maintenance because batteries leak and have to be substitute as often as every five years.

3. REVIEW OF LITRETURE:

Paliwal, M et.al [4] introduced a modeling and simulation of a dynamic voltage restorer as a voltage sag mitigation device in electrical power distribution networks. The dynamic voltage restorer is installed between the supply and a critical load feeder, for compensate for voltage sags/swells, restoring line voltage to its nominal value within few milliseconds and hence avoiding any power disruption to the load. The technical aspect related to the feasibility of dynamic voltage restorer (DVR) of traditional DC storage systems was evaluated based on constant DC voltage across the DC link during the process of voltage compensation. The modeling of dynamic voltage restorer was carried out based on the component wise and their performance was analyzed using MATLAB software. The simulation results prove that the control technique is very effective and yields excellent compensation for voltage sag mitigation in comparison with the existing algorithms.

T.Devaraju et. al.. [8] Suggested that quality of power issue endures incident shown in instability voltages, frequency either current which ends the collapse of equipment's. Main distribution systems, sensitive in industrial type loads, along crucial industrial surgeries suffer from all several kinds of service and outages interruptions that may lead to substantial loss of cost per episode fundamentals procedure is less time, less generation, lowly workforce power, along with rather than aspects. Within transient have been presents to be subsequent both power controllers: effective supply to DSTATCOM, as well as also the dynamic voltage restorer (DVR).

Paliwal, M et.al [9] introduced a modeling and simulation of a dynamic voltage restorer as a voltage sag mitigation device in electrical power distribution networks. The dynamic voltage restorer is installed between the supply and a critical load feeder, for compensate for voltage sags/swells, restoring line voltage to its nominal value within few milliseconds and hence avoiding any power disruption to the load. The technical aspect related to the feasibility of dynamic voltage restorer (DVR) of traditional DC storage systems was evaluated based on constant DC voltage across the DC link during the process of voltage compensation. The modeling of dynamic voltage restorer was carried out based on the component wise and their performance was analyzed using MATLAB software. The simulation results proves that the control technique is very effective and yields excellent compensation for voltage sag mitigation in comparison with the existing algorithms.

Thenmozhi et.al [2] introduced a design for load side compensation topology of Dynamic Voltage



Restorer using Z-source Inverter which is able to compensate voltage sag and swell at sensitive load terminals. Based on this topology, the DVR consists of uncontrolled rectifier for giving DC supply to Z-Source converter through DC link. Z-Source Converter based topology is proposed in order to enhance the voltage restoration property of the device. By controlling the shoot through capability of ZSC system using IGBTs provide ride-through capability during voltage sag, swell and provides high reliability. Additionally, a control scheme called Hysteresis Voltage loop controller is proposed to synthesis the desired injecting voltage. The simulation results show that the proposed DVR system exhibits an effective means for the compensation for voltage sag and swell in comparison with existing DVR designs for load side.

Madhusudan, R et.al. [8] presented a new systematic framework based on Sinusoidal Pulse Width Modulation (SPWM) technique for the modeling and simulation of a Dynamic Voltage Restorer (DVR) addressing power quality problems, voltage sag and swell. This framework effectively addressed the major problems like voltage sag and swell using custom power devices, Dynamic Voltage Restorer (DVR) a custom power device efficient and effective used in power distribution networks.

Mishra S.P et.al. [9] presented a new framework that addresses mitigation of voltage sags and swells focusing on non linear loads by incorporating Dynamic Voltage Restorer (DVR) focusing on the control of compensation voltages injected by DVR based on a-b-c to d-q-0 algorithm. The Dynamic Voltage Restore (DVR) introduced is simple to design, cost effective and offers a successful answer for the shield of responsive loads from voltage sags and swells. Computer simulations were carried out using MATLAB/SIMULINK software that proves that they offer the effective control technique suitable for non-linear loads in adverse conditions with reference to the other algorithms.

In [10] W. Jing et.al a survey on control strategies of Dynamic Voltage Restorer (DVR) is presented. Authors report that the inverter is the core component of DVR, this reference presents the inverter control strategies used in DVR recently, which are linear control and Non-linear control and their types

In [11] Suxuan Guo presented a fast repetitive controller based feedback control loop for dynamic voltage restorer (DVR) system is proposed. The Author reports that the fast repetitive controller has fast dynamic response when compared with traditional repetitive controller and Simulation results demonstrated the validity of proposed control system to mitigate voltage sag and maintain load voltage constant.

Biricik, S et.al [12] proposed a new method to improve the voltage compensation performance of Dynamic Voltage Restorer by using Self Tuning Filter. This control method gives an adequate voltage compensating even for 50% voltage sag and distorted voltage conditions. The DVR control method was modeled using MATLAB/Simulink, during the simulation in both off-line and real-time environment conditions proved that performance of DVR was improved significantly.

Abdollahzadeh, H., Jazaeri, M., & Tavighi, A [13] proposed a new fast-converged estimation approach, which directly extracts amplitudes and phase angles of symmetrical components of desired frequencies from harmonic-distorted network voltages. Simulations results were done to analyzed sensitivity against the impacts of phase angle jumps, sag depth variations and frequency variations. The performance of the proposed algorithm proves it applicable in Dynamic Voltage Restorer (DVR) as it offers adequate convergence time and accuracy. Further, comparative analysis was presented between the proposed approach and well-known algorithms such as KF, ADALINE and FFT using MATLAB/SIMULINK which confirms the effectiveness of the suggested control scheme. The proposed control scheme effectively provides the compensation of different voltage sags through both pre-sag and in-phase strategies.

Badrkhani Ajaei. F et. al. [14] introduced and evaluated an auxiliary control strategy for downstream fault current interruption in a radial distribution line by means of a dynamic voltage restorer (DVR). The novel controller was introduced which was effective in supplementing the voltage-sag compensation control of the DVR. Unlike several existing system, this framework independently controls the magnitude and phase angle of the injected voltage for each phase and does not require phase-locked loop. We incorporated a fast least error squares digital filters to estimate the magnitude and phase of the measured voltages and effectively reduce the impacts of noise, harmonics, and disturbances on the estimated phasor parameters, and this enables effective fault current interrupting even under arcing fault conditions.

4. CONCLUSION:

This paper a widespread review of publications presenting the topology, control scheme and implementation of UPQC for electrical power quality improvement. The study finds UPQC is an efficient custom power device used for maintaining good power quality of supply to the consumer by correcting various parameters like voltage sag, voltage swell, harmonics etc. By the process hybridization of previously implemented FACTS devices UPQC is designed which makes it more reliable.



REFERENCES

- [1] R. Amrita, and A. K. Nadir "Modeling & Simulation of dynamic voltage restorer (DVR) for enhancing voltage sag", *Sensors & Transducers Journal*, Vol. 87, Issue 1, January 2008, pp. 85-93, 2008.
- [2] R. Omar, and N. A. Rahim "Modeling and simulation for voltage sags/swells mitigation using dynamic voltage restorer (DVR)", *Power Engineering Conference*, 2008. AUPEC '08. Dec.2008, pp. 1-5.
- [3] C. Benachaiba, and B. Ferdi "Voltage quality improvement using DVR", *Electrical Power Quality and Utilization*, Journal Vol. XIV, No. 1, pp. 39-45, 2008.
- [4] M. F. Kangarlu, S. H. Hosseini, A. K. Sadigh "Transformer less DVR topology based on multilevel inverter with reduced number of switches" 1st Power Electronic & Drive Systems & Technologies Conference, IEEE, pp. 371-375, 2010.
- [5] A. Almeida, L. Moreira, J. Delgado, "Power quality problems and new solutions", *The electrical and computer engineering*, pp. 1-9, 2003.
- [6] A. Almeida, L. Moreira, J. Delgado, "Power quality problems and new solutions", *The electrical and computer engineering*, pp. 1-9, 2003.
- [7] R. C. Dugan, M. F. McGranaghan, and H. W. Beaty, *Electric Power Systems Quality*, 2nd ed. New York, NY, USA: McGraw-Hill, 2006.
- [8] Madhusudan, R., & Rao, G. R. (2012, March). Modeling and simulation of a Dynamic Voltage Restorer (DVR) for power quality problems-voltage sags and swells. In *Advances in Engineering, Science and Management (ICAESM)*, 2012 International Conference on (pp. 442-447). IEEE.
- [9] Mishra, S. P., Varghese, L., Roselyn, J. P., & Devaraj, D. (2013, October). Mitigation of Voltage Sags and Swells by Dynamic Voltage Restorer. In *Advanced Materials Research* (Vol. 768, pp. 338-343).
- [10] W. Jing, X. Ai Qin, S. Yueyue, "A survey on control strategies Of Dynamic Voltage Restorer", 13th IEEE International Conference on harmonics and quality of power, pp. 1 – 5, 2008.
- [11] Suxuan Guo, "Fast repetitive controller based low-voltage Dynamic Voltage Restorer for Voltage-Quality Issues in Distribution System", 2010 2nd IEEE International Symposium on Power Electronics for Distributed Generation Systems, pp. 988 – 992, 2010.
- [12] Biricik, S., Khadem, S. K., Redif, S., & Basu, M. (2014, June). Control of the Dynamic Voltage Restorer to improve voltage quality. In *Power Electronics for Distributed Generation Systems (PEDG)*, 2014 IEEE 5th International Symposium on (pp. 1-5). IEEE.
- [13] Abdollahzadeh, H., Jazaeri, M., & Tavighi, A. (2014). A new fast-converged estimation approach for Dynamic Voltage Restorer (DVR) to compensate voltage sags in waveform distortion conditions. *International Journal of Electrical Power & Energy Systems*, 54, 598-609.
- [14] Badrkhani Ajaei, F., Farhangi, S., & Iravani, R. (2013). Fault current interruption by the dynamic voltage restorer. *Power Delivery*, IEEE Transactions on, 28(2), 903-910.