



“A Review on Heat Transfer Augmentation in Circular Tube”

Neeraj kumar Nagayach¹

¹Neeraj Kumar Nagayach, Asst. Professor, Department of Mechanical Engineering, OIST, Bhopal

Abstract - The present paper is a review of research work of heat transfer growth in circular tubes for laminar and turbulent flow. Active as well as passive methods are employed for increasing the heat transfer coefficient in circular tube; Passive methods do not require application of external power such as active method require. The effectiveness of both active and passive methods depends strongly on the mode of heat transfer, which might range from single phase free convection to dispersed flow film boiling. Passive techniques, where inserts are used in the flow passage to augment the heat transfer rate, are advantageous compared with active techniques, because the insert manufacturing process is simple and these techniques can be easily employed in an existing heat exchanger. In design of compact heat exchangers, passive techniques of heat transfer augmentation can play an important role if a proper passive insert configuration can be selected according to the heat exchanger working condition (both flow and heat transfer conditions). The thermohydraulic behavior of an insert mainly depends on the flow conditions means flow is laminar or turbulent apart from the design of insert. This review paper is organized in the two sections: Insert in laminar flow and insert in turbulent flow.

Keywords - Circular tube, Heat transfer Augmentation, laminar and turbulent flow, Heat Transfer Coefficient, Friction factor.

I. INTRODUCTION

A heat exchanger is a complex device that provides the transfer of thermal energy between two or more fluids,

which are at different temperatures and thermally Contact with each other. Heat exchangers are used either individually or as components of a large thermal system, wide variety of commercial, industrial and household applications, e.g. power generation, refrigeration, ventilating and air-conditioning systems, process manufacturing, aerospace industries, electronic chip cooling as well as in environmental engineering. The improvements in the performance of the heat Exchanger have attracted many researchers for a long time as they are of great technical, economical and not the least, ecological importance.

“Heat transfer Augmentation” means Increase in heat exchanger’s performance with the help of augmentation techniques, this can lead to more economical design of heat exchanger that can also help to make energy, material and cost savings related to a heat exchange process. In this review paper emphasis is given on inserts used in for the augmentation of heat transfer in tube. The subject of heat transfer growth in heat exchanger is of serious interest in the design of effective and economical heat exchanger Bergles et al., identified about 14 augmentation techniques used for the heat exchangers. These augmentation techniques can be classified into passive, active and compound techniques. Passive techniques do not require any type of external power for the heat transfer augmentation such as coating of Surface, rough surface, extended surface, displaced insert, swirl flow device, surface flow device, surface tension, additives for liquid, and additives for gases. Whereas, the active techniques need some power externally, such as electric or acoustic fields, surface vibration, mechanical aid, fluid vibration, injection, suction, jet impingement, etc., and compound technique are the combination of this two method.



II. CIRCULAR TUBES FITTED WITH INSERT IN LAMINAR FLOW

This review paper involving recent research work on heat transfer growth in circular tube. many studies were conducted previously to analyze heat transfer growth in circular tube with laminar flow.

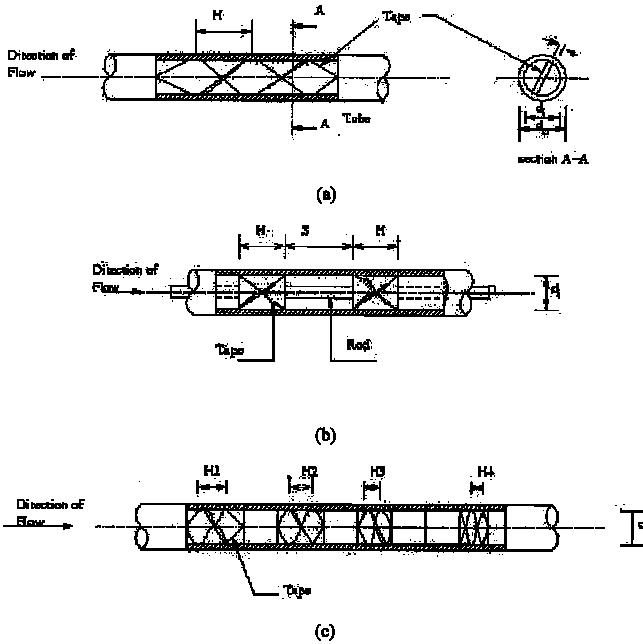

Fig 2.1 (a) full-length twisted tape, (b) regularly spaced twisted tape and (c) smoothly varying (gradually decreasing) pitch full-length twisted tape

[1] Sheeba et al., investigated the thermal performance of thermosyphon solar water heater system fitted with helical twisted tape of various twist ratios. conclusions made from the results that heat transfer enhancement in twisted tape collector is higher than the plain tube collector with minimum twist ratio and gradually decreases with increase in twist ratio in laminar flow [2] Eiasma Ard et al., investigated the behavior of heat transfer and friction loss in circular tube and they found that apart from the friction factor, heat transfer rate can be substantially improved by using both the wavy surfaced wall and the helical tape insert. [3] P Selvaraj et al., used water and ethylene glycol mixture 90:10 (by weight) flow through the circular tube because ethylene glycol prevents corrosion and acts as antifreezing agent. They investigate that the maximum heat transfer enhancement is obtained up to 36% for circular Tube in laminar flow with grooved inserts as compare to simple tube with turbulent flow. [4] Veysel Ozceyhan et al., investigate the heat transfer enhancement

in a tube with the circular cross sectional ring, uniform heat flux was applied to the external surface of the tube and their findings as follows:

The variation of Nusselt number, friction factor and overall enhancement ratios for the tube with rings were presented and the best overall enhancement of 18% was achieved.[5]P.K. Nagarajana et al., used 300 mm right-left helical twist with 100 mm spacer of different twist ratio on their investigation and found that Nusselt number for the tube fitted with 300 mm right-left helical twist is higher than that for plain tube for a given Reynolds number attributing to heat transfer enhancement due to swirl flow inside of tube. [6] J P Meyer and J. A Olivier investigated the heat transfer and pressure drop characterizes for enhanced tube with helical coil insert. There investigation covered the laminar, transitional and turbulent flow regimes. They found the better heat transfer in the laminar flow as compare to turbulent in heat transfer tube.

[7] Timothy et al., performed an experimental study of a double pipe helical heat exchanger used coil tape insert with laminar flow of fluid. They found that increase in Nusselt number significantly in the entrance region and heat transfer rates were higher in counter flow configuration as compared to parallel flow. [8] M E Ali investigates that average heat transfer coefficient increases as number of coil turns decrease for a fixed diameter ratio in laminar flow. [9]Veeresh Uskele and R M Sarviya experimentally studied the heat transfer and friction factor characteristics of double pipe and plane tube heat exchanger. They found that heat transfer coefficient and friction factor increase with the decrease in twist ratio compared to plain tube in laminar flow.

[10] P. Sivashanmugam and S.Suresh studied the laminar heat transfer and friction factor characteristics in a circular tube fitted with full length helical screw tapes with different twist ratios under constant heat flux conditions, They reported significant improvement of the heat transfer rate for using the tape inserts and found that there is not much change in the magnitude of heat transfer coefficient to vary twist ratio sets. [11] Ujhidy et al., have studied and proposed Dean Number. Dean Number is a measure of the magnitude of the secondary flow, which is useful for the future investigation of heat transfer growth in circular tubes contained twist tape in laminar flow.

[12]Suresh Kumar et al. investigated the thermohydraulic performance of twisted tape inserts in a large hydraulic diameter annulus and found that thermohydraulic performance in laminar flow with a twisted tape is better than the wire coil for the same helix angle and Thickness ratio.



III. CIRCULAR TUBES FITTED INSERT IN TURBULENT FLOW

Investigation of heat transfer augmentation insert used in turbulent flow circular tubes discussed in this section. Heat transfer augmentation insert in turbulent flow is effective up to certain Reynolds number. More Reynolds number blocks the flow passage and increases the pressure drop

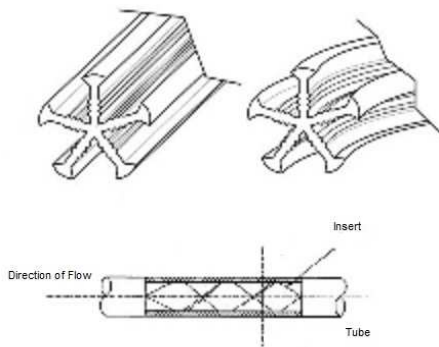

Fig 3.1 Turbulent flow generator in circular tube

[13] W. Noothong et al., studied influences of insert in a concentric double pipe heat exchanger. The turbulent flow was introduced by using twisted tape in the flow direction with different twist tape ratio; result shows that's twist ratio increases heat transfer rate as compare to plain tube in turbulent flow. [14]M.A.K. Chowdhuri et al., used special geometry inside of tube with turbulent flow. The test section is electrically heated and air is allowed to flow as the working fluid through the tube by means of blowers. Same experiment is carried out to determine heat transfer through the same tube without any insert. Comparing the results obtained from these two different sets of experiments and found that heat transfer through tubes can be enhanced by using inserts inside the tube up to 9.8 times than tube without insert with turbulent flow in circular tube. [15] P. Sivashanmugam and S. Suresh investigated heat transfer and friction factor characteristics of circular tubes fitted with full length helical screw element of different twist ratio with heat flux under turbulent flow conditions, they investigate that maximum performance of the helical twist insert was achieved as compare to twisted tape insert in turbulent flow. [16] P. Murugesan et al. reported experimental investigations of heat transfer and friction factor for turbulent flow in a tube fitted with trapezoidal cut twisted tape. There observation says that that heat transfer coefficient and friction factor increases with the decreases in twist ratio. The trapezoidal cut twisted tape with twist ratios increases the heat transfer rate 41.8 % higher than plain tubes. [17] P. Coronel and

K.P. Sandeep conducted experiments in helical heat exchangers with coils of two different curvature ratios, straight tubular heat exchangers at various flow rates and for different end point temperatures. The inside and outside convective heat transfer coefficients were determined based on overall heat transfer coefficient and a correlation to compute the inside convective heat transfer coefficient as a function of Reynolds number. [18]M. Mridha and K P D Nigam investigated turbulent forced convection in a new device of coiled flow inverter and found 4-13% enhancement in heat transfer as compared to straight helical coil while relative pressure drop was found to be 2-9%. Further, gain in heat transfer in coiled flow inverter for turbulent flow condition as compared to straight tube for same flow rate and boundary condition was 35-45% while increase in pressure drop found 29-30%. [19] Smith Eiamsa-ard et al., presented an experimental study on the mean Nusselt number friction factor efficiency in a round tube with short-length twisted tape insert under uniform wall heat flux boundary conditions. In the experiments, measured data are taken at Reynolds numbers in a turbulent region with air as the test fluid. The experimental result indicates that the short-length tapes perform lower heat transfer and friction factor values than the full-length tape around 14%, 9.5% and 6.7%; and 21%, 15.3% and 10.5% respectively. [20] Sharma et al., Conducted experiments to evaluate heat transfer coefficient and friction factor for turbulent flow in a tube with twisted tape inserts in the transition range of flow with Al203 nanofluid are conducted. The results showed considerable enhancement of convective heat transfer with Al203 nanofluids compared to flow with water. [21] C Thianpong et al., investigated experimentally heat transfer and friction characteristics for water, ethylene glycol, and ISO VG46 turbine oil flowing inside four tubes with three-dimensional internal extended surfaces and segmented twisted-tape inserts. Investigation shows that tube with three-dimensional internal extended surfaces and twisted-tape inserts; enhance the convective heat transfer for the turbulent tube side flow of highly viscous fluid.

IV. CONCLUSION

This review paper discusses the considerable experimental work which has been done on heat transfer augmentation through internal inserts in circular tubes. Some kind of internal insert like helical tap insert, wire mesh tape insert etc., placed in the flow passage of a tube to augment the heat transfer rate. This inserts mixes the bulk flow well and therefore performs better in laminar flow. However in laminar flow the thermal resistance is not limited to a thin region. Hence, it is concluded that inserts are effective in laminar flow. Turbulent flow is



effective up to a certain Reynolds number because more Reynolds number block the flow and increases the pressure drop which is the cause of lower heat transfer. Turbulent flow is more frequently encountered than laminar flow so a great change of local heat transfer rate in separated flow region is achieved and considerable heat transfer augmentation may result up to reattachment region.

However, the question of scalability remains unanswered because of practical difficulties in experimental work. There is a need of analyzing dynamics similarities amongst the geometrical similarities on large scale model covering industrial application. Further research is required to be conducted at a large scale on considerable range of curvature ratio, low range of curvature ratio, low range of Prandtl number and low Reynolds numbers, temperature etc.

V. REFERENCES

- [1] K. N Sheeba, Experimental studies on heat transfer and friction factor characteristics of forced circulation solar water heater system fitted with helical twisted tapes, *Communicated by Associated Editor Brian Norton*, 2009.
- [2] S Eiamsa-ard and P Promvonge, Enhancement of Heat Transfer in a Circular Wavy surfaced Tube with a helical tape Insert, *International energy Journal*, 2007, pp29-36
- [3] P Selvaraj, J Sarangan and S Suresh, Experimental investigation on heat transfer and friction characteristics of a water and ethylene glycol mixture flow of internally grooved tube, *International Journal of chemical Research*, 2011 pp33-40.
- [4] Veysel Ozceyhan, Sibel Gunes, Orhan Buyukalaca and Necdet Altuntop, Heat transfer enhancement in a tube using circular cross sectional rings separated from wall, *Applied Energy*, 2008, pp988-1001.
- [5] P. K Nagarajan and P Sivashanmugam, Heat Transfer Enhancement Studies in a Circular Tube Fitted with Right-Left Helical Inserts with Spacer. *World Academy of Science Engg. & Tech*. 2011.
- [6] J.P Meyer and J A Olivier, Transitional flow inside enhanced tubes for fully developed and developing flow with different types of inlet disturbances, *International Journal Heat Mass Transfer*. 2011, pp1598–1600.
- [7] T J Rennie and GSV Raghavan, Thermally dependent viscosity and non Newtonian flow in a double pipe helical heat exchanger, *Applied Thermal Engg*. 2007, pp862–868.
- [8] M. E Ali, Natural convection heat transfer from vertical helical coils in oil, *International J Heat Transfer and Engineering*. 2006, 79-85.
- [9] Veeresh Uskele and R M Sarviya, Heat transfer and pressure drop in double pipe heat exchanger with wire mesh insert, *International Conference on Thermal Fluid and Manufacturing Sci*. Jan 20-21, 2012 Gujarat- India.
- [10] P Sivashanmugam and S. Suresh, Experimental studies on heat transfer and friction factor characteristics of turbulent flow through a circular tube fitted with helical screw-tape inserts. *Chemical Engg and processing*. 2007, pp1292–1298.
- [11] A Ujhidy, J Nemeth and J Szepvolgyi, Fluid flow in tubes with helical elements, *Chemical Engg and processing*, 2003, pp 1–7.
- [12] P Suresh Kumar, P Mahanta, and A Dewan., Study of laminar flow in a large diameter annulus with twisted tape inserts, *International Conference on Heat transfer Fluid Mechanics and Thermodynamics, Victoria falls Zambia- 2003*. Paper No. KP3.
- [13] W Noothong, S Eiamsa-ard and P Promvonge., Effect of twisted tape inserts on Heat Transfer in a Tube. *The 2nd joint International conference on sustainable Energy and Environment- Bangkok-2006*, pp1-5.
- [14] M. A. K Chowdhuri, R. A Hossain and M.A.R Sarkar, Experimental investigations of turbulent flow heat transfer through tube with rod-pin insert. *International Journal of Engg Science and Tech*, 2011, pp76-81.
- [15] P Sivashanmugam and S Suresh. Experimental studies on heat transfer and friction factor characteristics of turbulent flow through a circular tube fitted with helical screw-tape inserts, *Chemical Engg and processing*, 2006, pp1292–1298.
- [16] P Murugesan, K Mayilsamy, S Suresh and P.S.S Srinivasan., Heat transfer and pressure drop characteristics of turbulent flow in a tube fitted with trapezoidal cut twisted tape insert. *International journal of Academics research*., 2009, 123-128.
- [17] P Coronel and K P Sandeep, Heat transfer coefficient in helical heat exchangers under turbulent flow conditions, *International Journal of food Engg.*, 2008, pp1-12.
- [18] M Mridha and K P D Nigam. Numerical study of turbulent forced convection in coiled flow inverter, *Chemical*



Engg processing. 2008, 893-905.

[19] Smith Eiamsa-ard, Chinarak Thianpong, Peterpics Eiamsa-ard and Pongjet Omvonge. Convective heat transfer in a circular tube with short length twisted tape. *International communication in Heat and mass Transfer*, 2009, pp363-371.

[20] K.V Sharma, L Sunder Shyam and P.K Sharma, Estimation of heat transfer coefficient and Friction factor

in transition flow with low volume concentration of Al₂O₃ Nano fluid flowing in a circular tube and with twisted tape, *International communication in Heat and mass Transfer*. 2009, pp503-507

[21] S. Eiamsa-ard, P. Eiamsa-ard and C Thianpong, Turbulent heat transfer enhancement by counter/co-swirling flow in a tube fitted with twin twisted tape, *Experimental thermal and fluid science*, 2009, pp 53-62.